

# TECHNICAL DATA SHEET

**D - 100 - 04**  
**4 1/2" HINGE PREPARATION**  
**1 3/4" DOORS**

## 4 1/2" HINGE PREPARATION 1 3/4" DOORS

HINGE PREPARATION WILL TAKE 4 1/2" HIGH TEMPLATE HINGES ONLY. NON-TEMPLATE HINGES CANNOT BE USED. STD/HVY

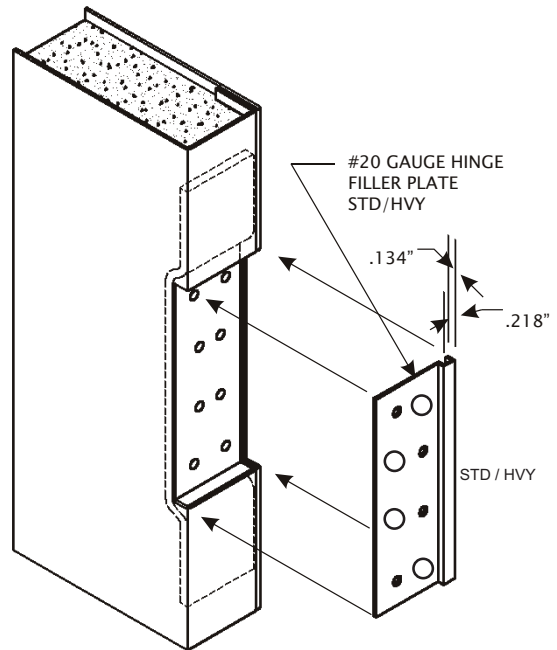
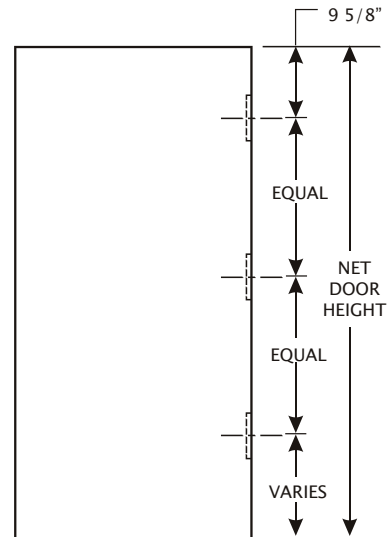
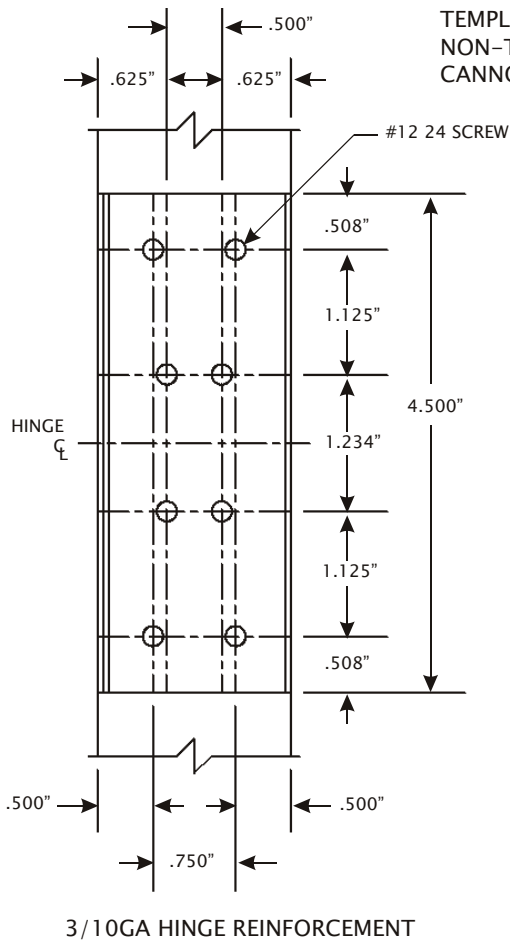

ALL DOORS ARE NOT HANDED

**Issue Date: January 2006**

REVISED : 02/01/2009

